



Omnidirectional Digital HDTV Over-the-Air Antenna

Installation and Operating Instructions



053225 (White)
053226 (Black)

Thank you for choosing a KING Antenna!

The KING OmniPro is an omnidirectional antenna.
It's *always* pointed in the right direction!

OPERATION

- 1 Turn on TV.**
Turn on the power inserter.*

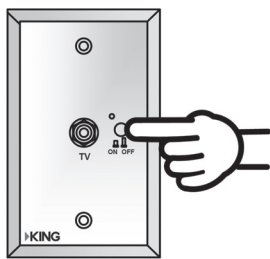

*You must have a properly installed KING wall mount power inserter to operate the KING OmniPro (included with this product).

**See your TV or converter box owner's manual for instructions on performing a channel scan.

Installation instructions start on next page.

- 2 Perform a channel scan.****

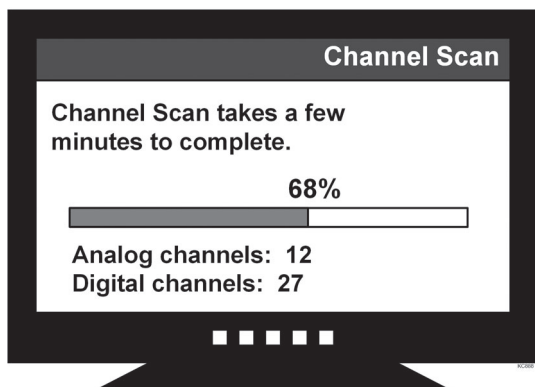

Sample screen: number of channels will vary

- 3 Start watching TV!**



ANTENNA INSTALLATION

IMPORTANT! The installer is responsible for determining and supplying the most appropriate fasteners to secure the antenna to the roof, and for weatherproofing all holes with roof-compatible sealant.

All holes and fastener heads must be sealed so they are completely waterproof.

1. Select an area on the roof for the base mount keeping in mind the following **IMPORTANT POINTS**:
 - a) The antenna must be mounted with the coax channel towards the rear of the vehicle.
 - b) The center of the roof hole must be at least 20" away from any object taller than 8" to provide clearance for the antenna head. The center of the roof hole must also be at least 8" from the edge of the roof.
2. Connect the coax from the power inserter's antenna input to the coax cable in the base mount. (The coax may come up thru the roof or enter thru the coax channel.)
3. Apply sealant to the base mount, and fill the coax channel with sealant. Place the base mount in position.
4. Fasten the base mount to the roof. Make sure the base mount is sealed all the way around. Make sure the coax channel and fastener heads are sealed as well.

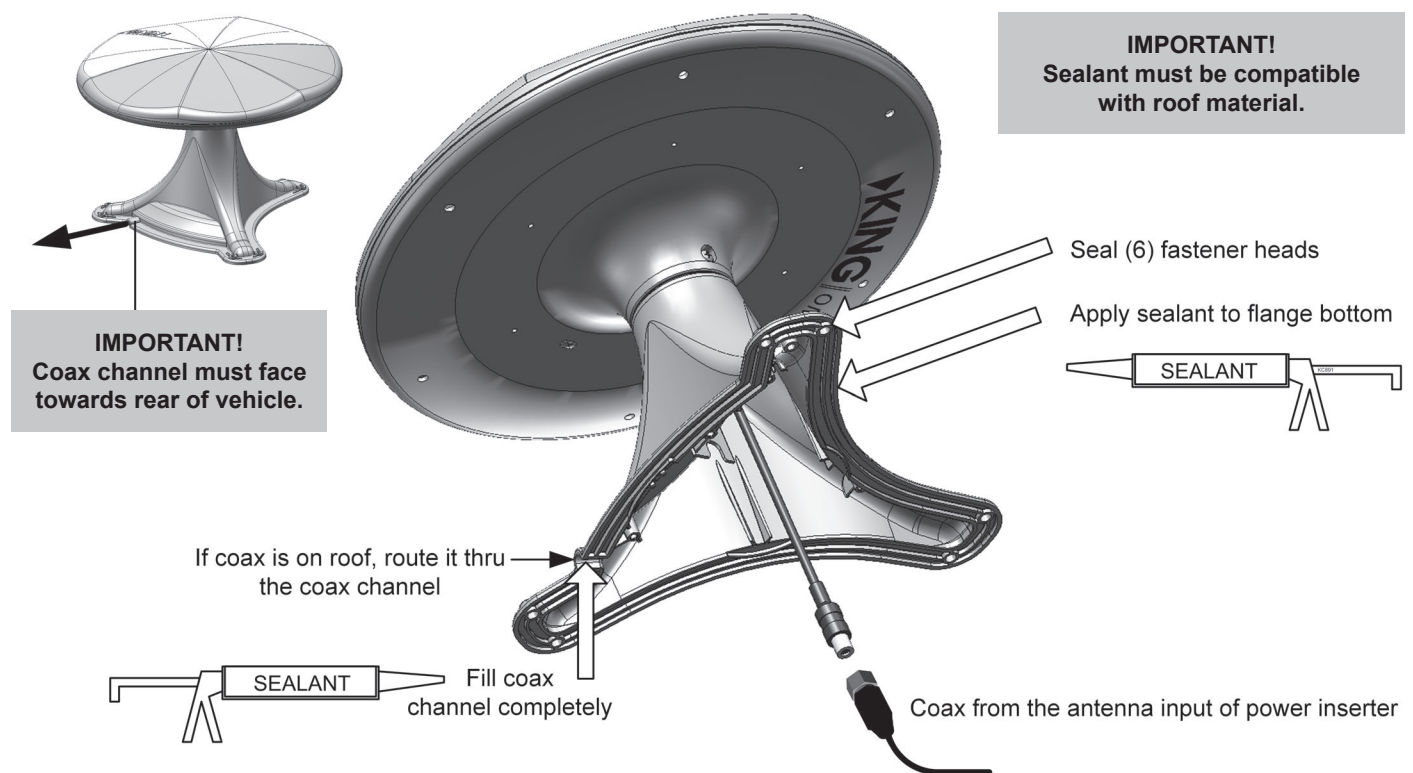

SPECIFICATIONS

SPECIFICATIONS	
Dimensions:	23cm H x 33cm W x 33cm L
Weight:	1 kg
Power requirement:	+12 Volt / 100 mA
Power supplied by:	KING Power Inserter (included with this product)
Enclosure/Mount:	ASA-Automotive grade
Frequency Bands:	VHF (174 to 230 MHz) UHF (470 - 698 Mhz)

ABOUT THE POWER INSERTER

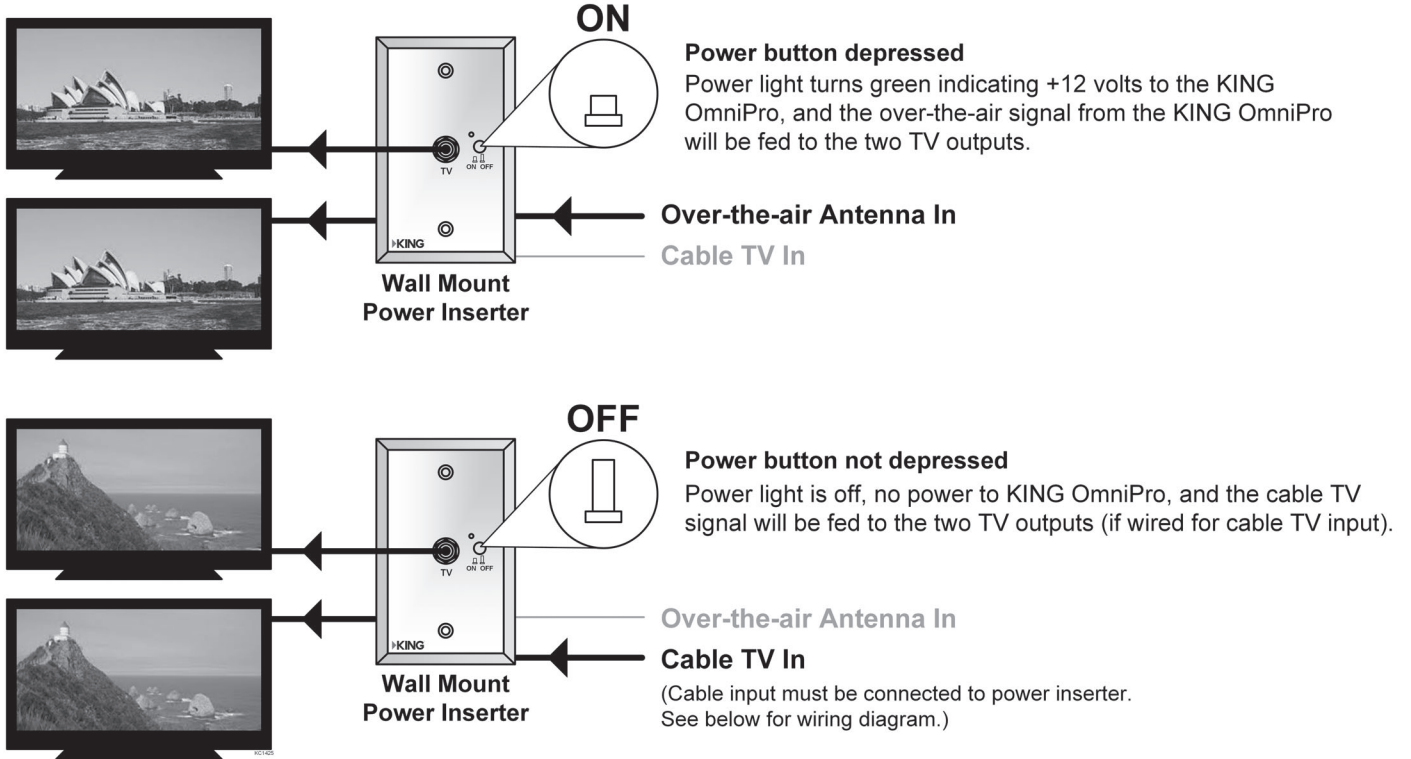

POWER INSERTER INSTALLATION

Keep in mind the following when installing the Wall Mount Power Inserter:

- Can be mounted in most standard electrical boxes.
- Requires a +12 Volt DC power source. (Inadequate voltage may cause the green LED to not illuminate and the unit to not function properly.
- Requires .25" female spade connectors for power and ground connections.
- Has an internal fuse rated @ 400 mA max. If tripped, the fuse will reset when the circuit cools.
- Is not an amplifier. No devices other than those shown below should be connected (unless approved by KING).

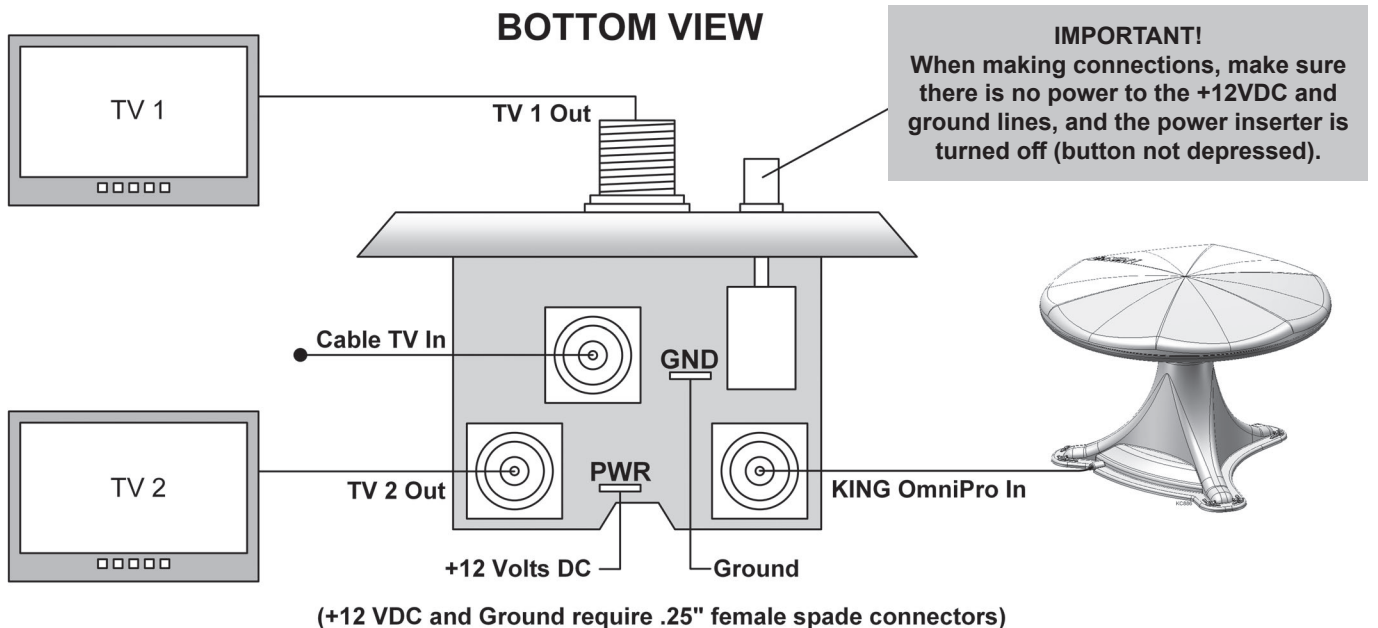

LIMITED WARRANTY

IMPORTANT! Do not power wash any part of the KING OmniPro antenna head or base mount.

Every new KING OmniPro Antenna System Model 053225 and 053226 is thoroughly inspected and tested before leaving the factory, and is covered by the following limited warranty from the date of original purchase:

- Two-year parts warranty: The customer is not responsible for the cost of replacement parts if the original part is determined to be defective under the terms of the warranty. The customer is responsible for the cost of replacement parts after two years.
- One-year labor warranty: The customer is not responsible for labor costs to repair unit if unit falls under the terms of the warranty. Any warranty labor outside of that performed at the factory is not covered unless the product has been installed by an authorized dealer/installer or OEM manufacturer. The customer is responsible for all labor costs after one year.

Should any trouble develop during the warranty period, contact the Australian/New Zealand distributor, Camec, before the warranty period expires. If a fault covered by the warranty occurs, the Purchaser must first contact Camec.

Contact with Camec may be made in any of the following ways:

- Australia: (a) Phone 1300 654 936, (b) Fax 03 9799 4476, (c) Email: camec@camec.com.au
- New Zealand: (a) Phone 64 9 257 2419, (b) Fax 64 9 255 1910

Any warranty claim from the Purchaser must be accompanied by:

- Proof of purchase
- Return of the product, and
- Full details of the alleged defect.

The cost of delivery and insurance of the Product to and from Camec and the cost of testing the Products are the responsibility of the Purchaser.

This warranty does not cover installation and external wiring, or remanufactured units. This warranty is not transferable from the original owner.

This warranty does not apply where:

- The product has been abused, misused, improperly installed or improperly maintained.
- The product has been used with an accessory other than a KING accessory designed for the product.
- Repairs have been made or attempted by others that are not certified by Camec to do such repairs.
- Repairs are required because of normal wear and tear.
- Alterations have been made to the product.
- The product or any associated component has been opened without authorization or disassembled to any degree.
- Damage has been caused by power washing.
- Circumstances beyond the control of Camec cause the product to no longer operate correctly.
- Customer is not the original owner.

In no event shall Camec be liable for any indirect, incidental, or consequential damages from the sale or use of the product. This disclaimer applies both during and after the term of the warranty. Camec disclaims liability for any implied warranties, including implied warranties of "merchantability" and "fitness for a specific purpose," after the term of the warranty.

Distributed by



Camec Pty Ltd - 47-63 Remington Drive, Dandenong South Victoria, Australia
Phone: 1300 654 936 Fax: 03 9799 4476
www.camec.com.au

Camec NZ Ltd - 44 Montgomerie Road, Mangere Auckland, New Zealand
Phone: 64 9 257 2419 Fax: 64 9 255 1910
www.camec.co.nz