

Optimal installation of Dometic 3 Way absorption refrigerators in caravans, motor homes and campers.

Dometic absorption refrigerators for caravans and motor homes and campers are built to provide excellent cooling performance, even in high ambient temperatures. Difficulties with the performance of the refrigerator can be avoided by installing it correctly and or by improving both the installation and ventilation of an existing installation.

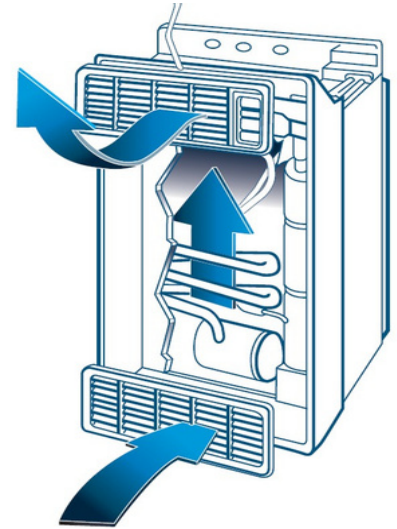

Proper installation is very important.

1. The installation and connections of gas supply must be made by an authorised gas fitter in compliance with the Australian Gas Authority regulations.
2. The location of the refrigerator should be such that the ventilation vents are not blocked by the vehicle door when open.
3. The refrigerator should be installed on a hard flat level surface.
4. The recess for the refrigerator should be sealed from the living area of the vehicle. No gas leak or exhaust gases can penetrate into the living area.
5. The space between the refrigerator cabinet and the furniture should be kept to a minimum. This is to exclude the warm air given off by the cooling unit from blanketing the cabinet. If possible fill any void with glass insulation wool down both sides and on top of the refrigerator cabinet.
6. Regardless of which option of ventilation method is used the following points must be followed.

a. The bottom of the lower vent must be at the floor level that the refrigerator cabinet is mounted on (The floor). If the lower vent is above the floor level a 40mm hole must be made through the floor to provide an escape for any possible gas leak.

b. The top vent must be mounted above the refrigerator cooling unit, the rule is **THE BOTTOM OF THE TOP VENT MUST BE AT THE VERY LEAST EQUAL TO OR ABOVE THE TOP OF THE REFRIGERATOR**. This is to ensure all of the air moving up through the vents will pass through the complete cooling unit.

Note: There are installations where it may not be possible to position the top vent completely above the top of the cabinet, this can be due to vehicle design restrictions. The refrigerator will still work, however for the best performance particularly in high ambient conditions the top vent should be above the cabinet.

7. A suitable metal warm air deflector plate should be fitted to direct the rising warm air from the cooling unit to the outside via the top vent. This deflecting plate should be as wide as possible and be fitted in such a way that it does not interfere with the wiring on top of the refrigerator cabinet.

Dometic 3wayRefrigeratorVentingoptions.

suitable for Motor homes, Caravans and Campers.

Option One..... Fig 1

Common vent system up to 100 lt.

Ventilation Components required are:

1 X AS1625 vent kit (top & bottom frames & vents)

Includes the aluminium flue connection

1 X TP (Includes 1 x Tee piece & 1 x extension)

extra extensions may be required dependent on the height of refrigerator and vent height. Part number TPX

Ventilation system for refrigerators up to 100 Litres capacity



AS1625 vent kit each vent has 328 cm² open area



TP Kit



TPX Extension

Note each TPX adds 43mm in height

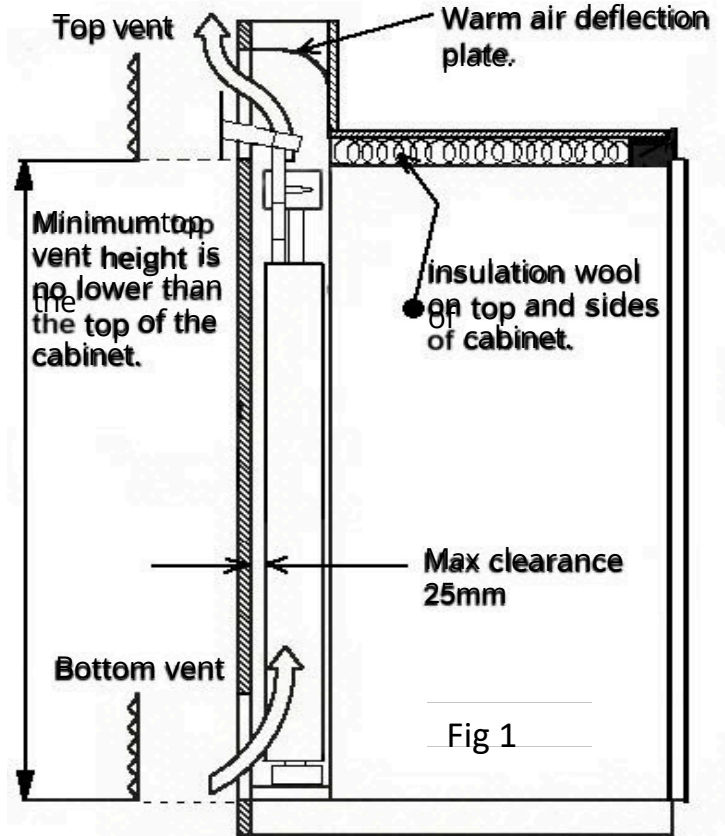

Option Two..... Fig 2

Common motor home ventilation system.

Ventilation Components required are.

1 x Motor home wall vent # 3109350.110

1 x Motor home roof base # 3311237.000

1 x Motor home roof cap # 3311246.000

1 x Gas flue kit # 3776

Ventilationsystemsfor refrigerators from 101 Litres up to 200 Litres .



Roof Cap & roof base open ventilation area of 730cm²



Gas flue kit # 3776

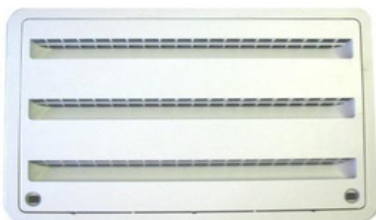

Motor home wall vent. Each vent has 450cm² open area.

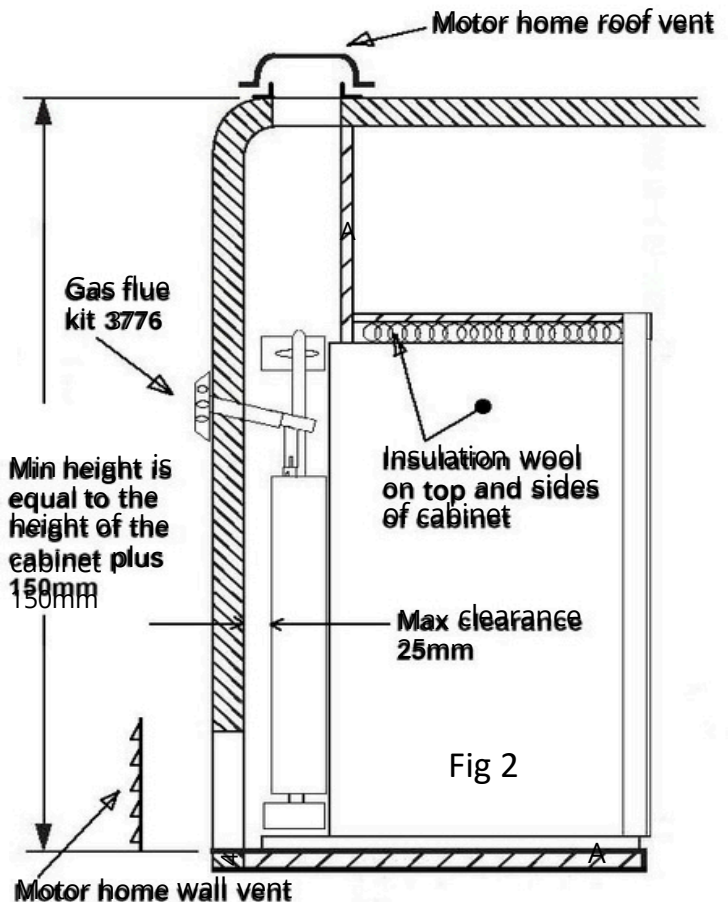

Option Three..... Fig 3
 Common motor home & caravan ventilation system.
 Ventilation Components required are.
 2 x Motor home wall vents # 3109350.110
 1x Gas fluekit#3776

Ventilation systems for refrigerators from 101 Litres up to 200 Litres capacity .

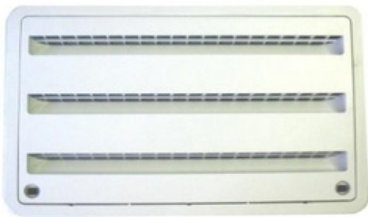

Motor home wall vent. Each vent has 450 cm² open area.



Gas flue kit # 3776

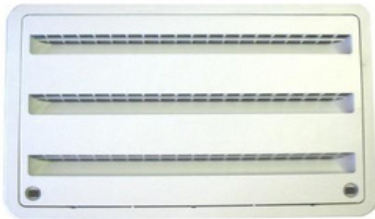

Motor home wall vent. Each vent has 450 cm² open area.

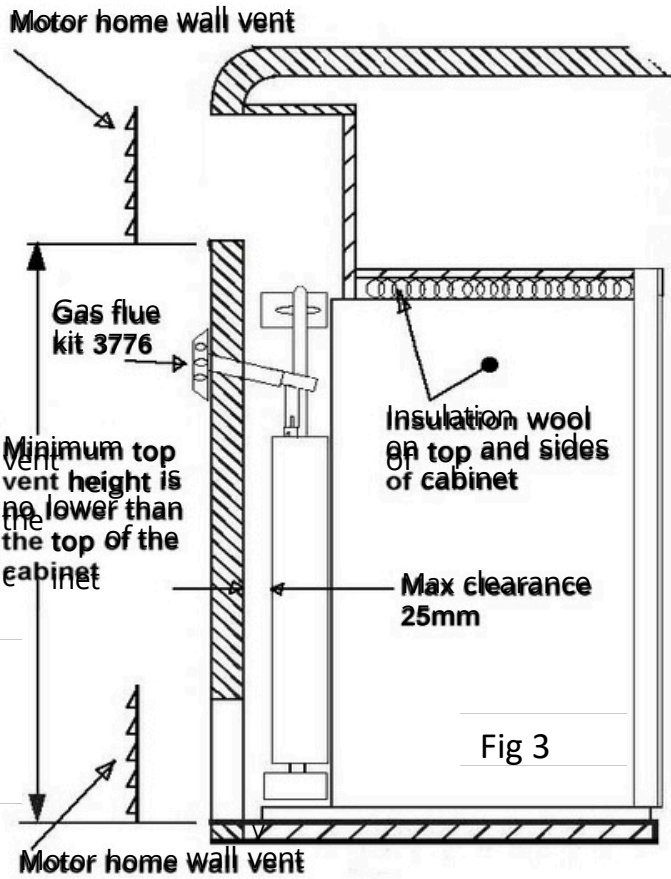

Option Four.....Fig4Common motor home & caravan ventilation system.

Ventilationsystemsfor refrigerators from101 Litres up to 200 Litres and greater than 200 Litres.

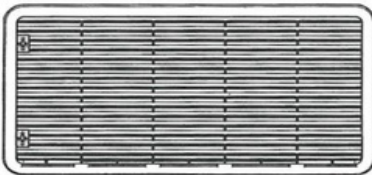

LS300 vent and frame cut out required 490mm x 249mm. Each vent has open area of 667 cm²



Gas flue kit # 3776



LS300 vent and frame cut out required 490mm x 249mm.Eachventhasopenareaof667cm²

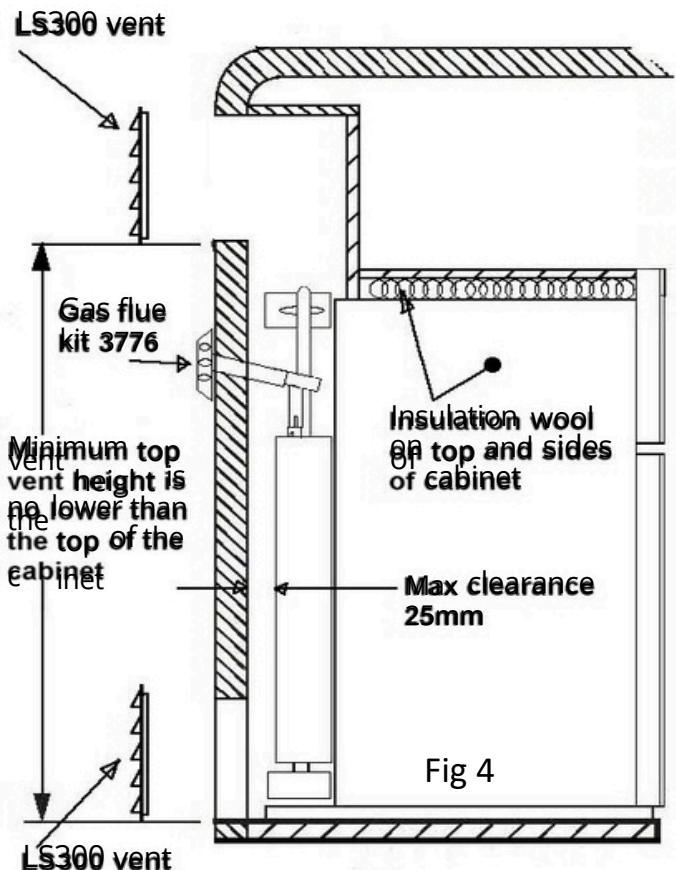

Dometic ventilation systems.

DometicRV ventilationsystems have beendesigned specifically to provide optimum ventilation and therefore significantly better cooling performance for all Dometic absorption refrigerators.

Technical data AS1625 vent kit....

Upper ventsetconsistsof:

Upper frame.....RS1640U
 Upper vent.....AS1625U
 Upper vent insert.....AS1625i
 Alum flue tube.....Alumtube

Lower vent set consists of:

Lower frame.....RS1650L
 Lower vent.....AS1635L

Mounting frame cut out size: Width 451 height 156

Open area of upper vent: 328 cm²

Open area of lower vent: 350 cm²



Gas flue Tee piece connection kit includes one extension: Part number ...TP



Gas flue extension each extension add 43mm to the height of the Tee piece. Part number... TXP

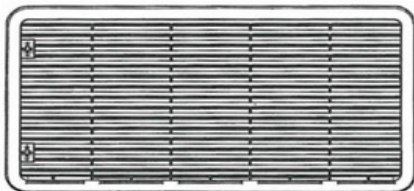

LS300 vent and frame cut out required 490mm x 249mm
 open ventilation area 667 cm²



Gas flue kit: Part number... 3776



Motor home vent roof cap: Part number ...3311246.000
 width: 310mm length: 670mm height:100mm

Combined with

Motor home vent roof base: Part number...3311237.000
 width: 210mm length:660 height: 95mm

Assembled over all dimensions...

width: 310mm length: 670 height: 125mm Open ventilation area: 730 cm²

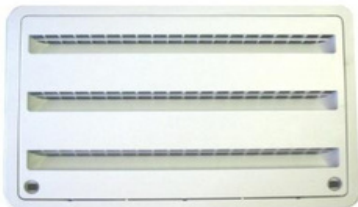

Motor home wall vent: Part number...3109350.110

Over all: width 587mm height:385mm

Cut out required: width: 550 height: 350mm

Clear opening with vent removed: width:556mm Height: 303mm

Open ventilation area: 4450cm²

Note: These ventilation options are intended to compliment the original installation and operating instructions supplied with each Dometic refrigerator and are the preferred ventilations systems for all Dometic absorption refrigerators.

Current AS/NZS 5601.2:2010 and future amendments to the gas installation regulations must be adhered to at all times.

Warranty claims due to incorrectly ventilated, installed or flued refrigerators are not covered by the usual Dometic two year Australian wide warranty. All details are subject to alteration without notice.